

M/134 Noble

90 ml / h: 66 mm / Ø 64 mm

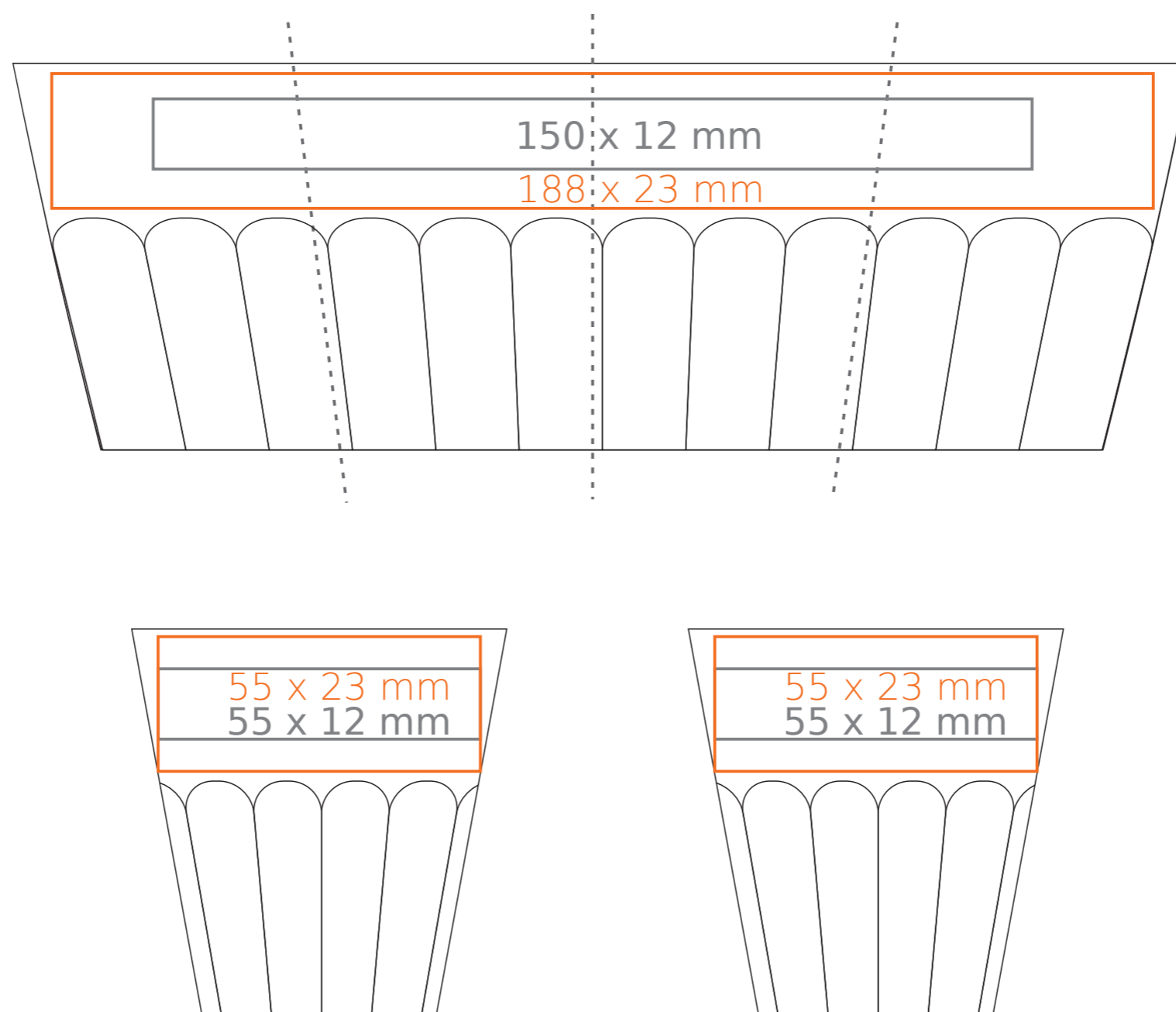

Imprint on the inside - 30 x 10 mm
 Imprint on the bottom inside - Ø 20 mm
 Imprint on the bottom outside - Ø 20 mm

*In the case of projects for transfer print running outside of the standard print area, please contact our sales department.

[How to prepare print material](#)

meaning

— Transfer Print
 — Sensitive Touch
 — Direct Print

M/134 **Noble**

260 ml / h: 95 mm / Ø 84 mm

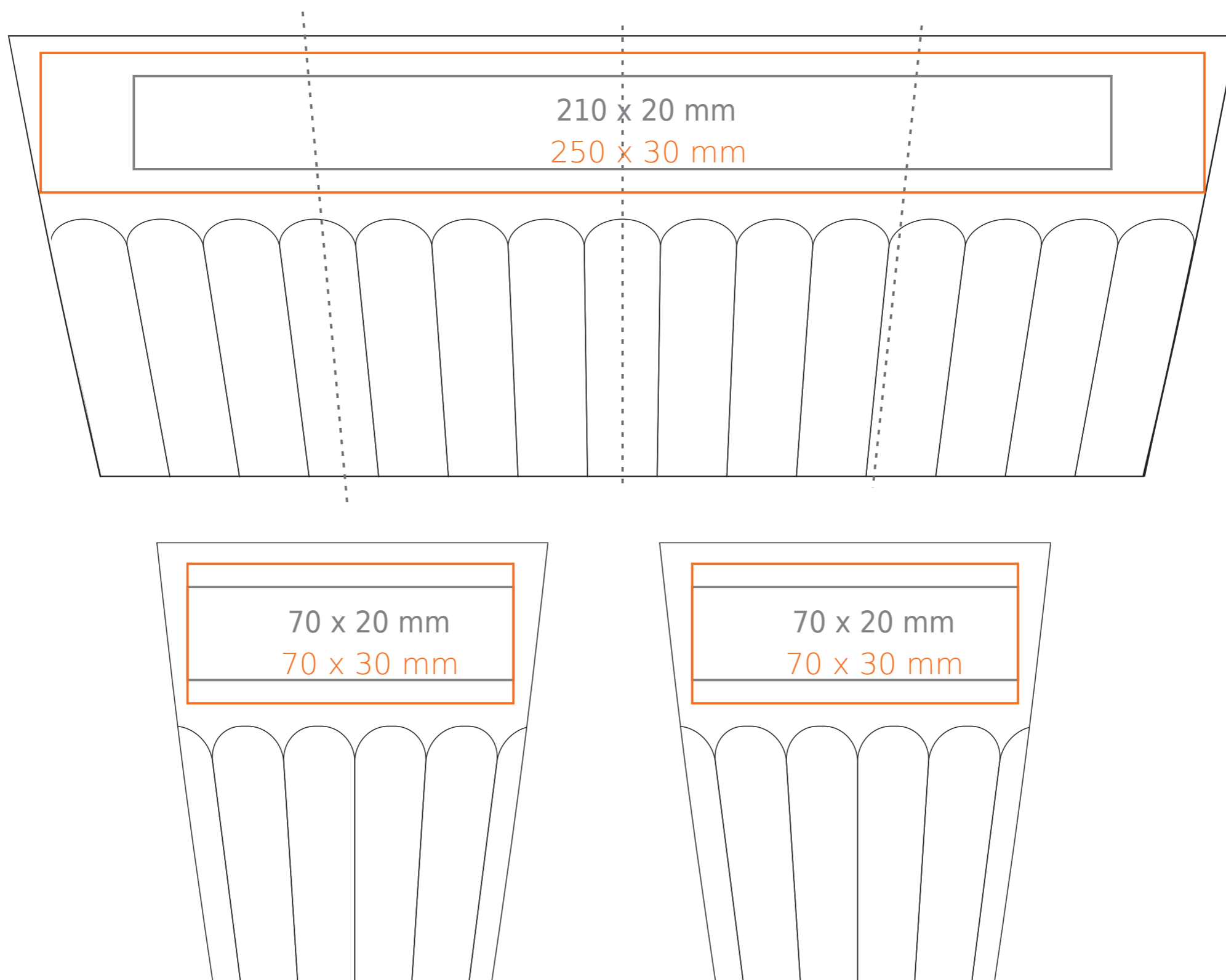

- | | |
|-------------------------------|--------------|
| Imprint on the inside | - 50 x 15 mm |
| Imprint on the bottom inside | - Ø 40 mm |
| Imprint on the bottom outside | - Ø 30 mm |

*In the case of projects for transfer print running outside of the standard print area, please contact our sales department.

[How to prepare print material](#)

meaning

- Transfer Print
- Sensitive Touch
- Direct Print

M/134 **Noble**

360 ml / h: 125 mm / Ø 87 mm

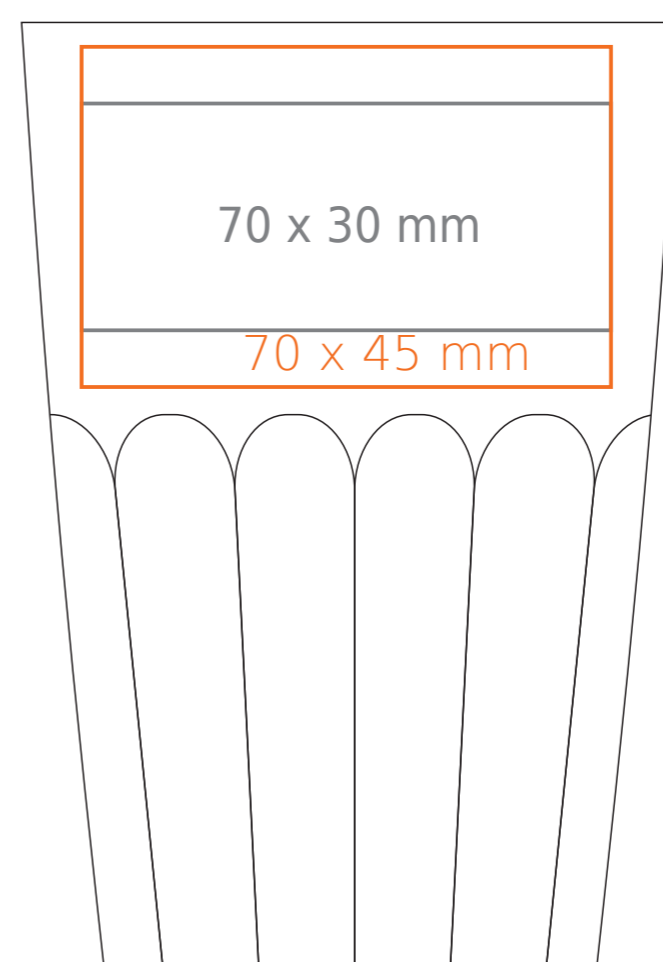
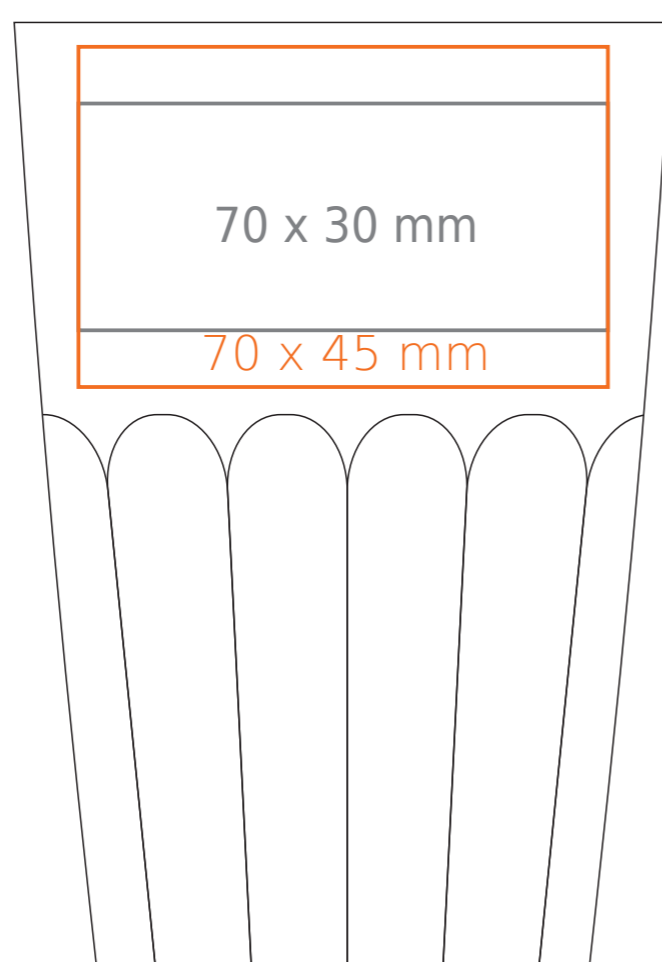
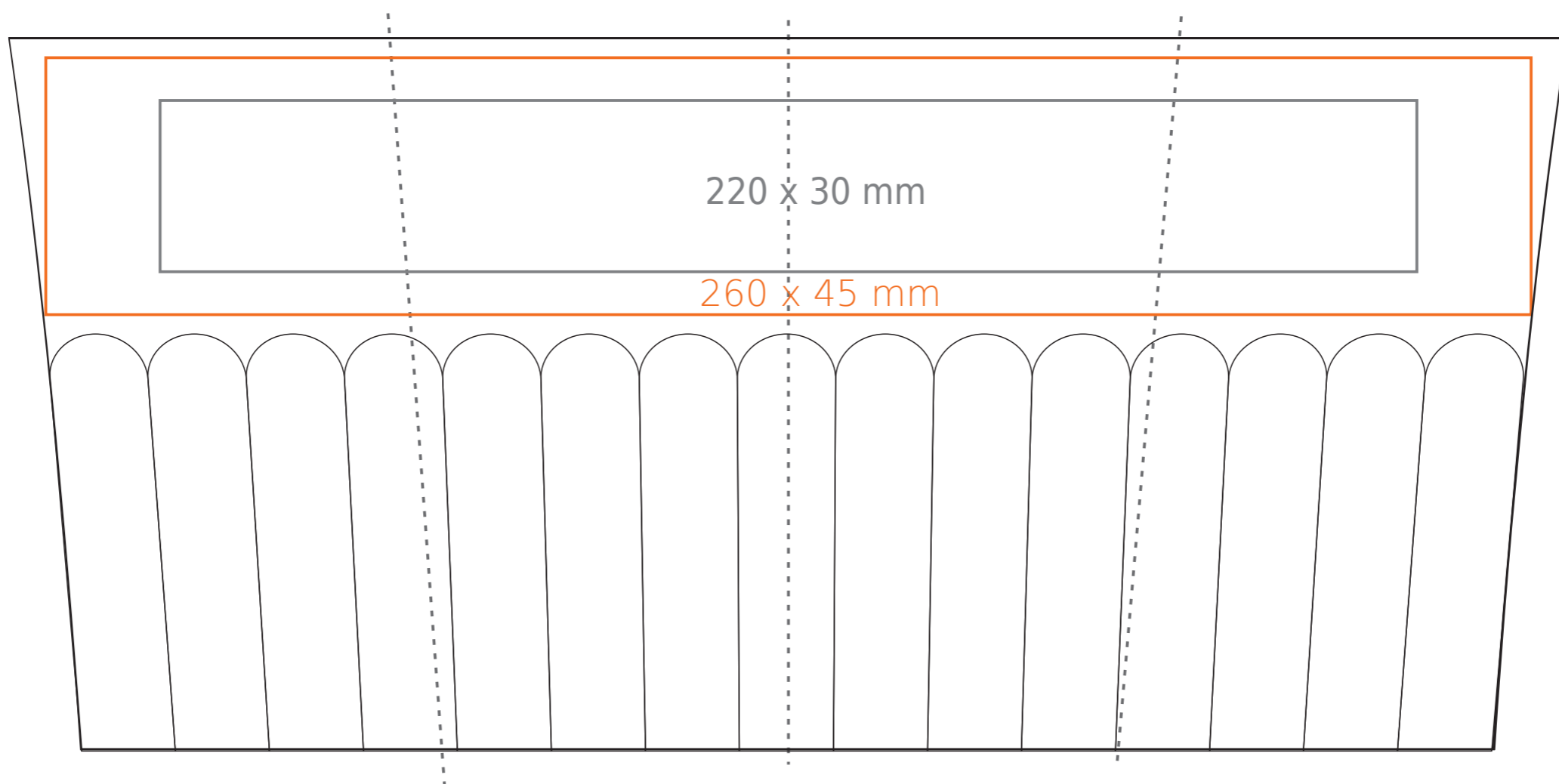

- Imprint on the inside - 50 x 15 mm
- Imprint on the bottom inside - Ø 40 mm
- Imprint on the bottom outside - Ø 30 mm

*In the case of projects for transfer print running outside of the standard print area, please contact our sales department.

[How to prepare print material](#)

meaning

- Transfer Print
- Sensitive Touch
- Direct Print